

(ENG) INSTALLATION, USE and MAINTENANCE GUIDEBOOK

BINDING MODEL: **SL EVO WORLD CUP – 110 GR**



PRODUCT SEGMENT: RACE

PRODUCT CODE: PTSLEVO

TOE PATTERN ON M05 JIG: P1-P1-P1-P1

HEEL PATTERN WITHOUT R01 (M05D): C-C-C-C



MAX SKI WIDTH UNDERFOOT: 85 MM

WARNING!

SEAL OF LIABILITY AND REMOVAL OF THE SAME

A “Seal of Liability” has been securely and carefully applied to each binding produced by ATK RACE S.R.L. during the packaging operations.

The removal of this seal **MUST BE EXCLUSIVELY PERFORMED** by the Original User itself.

The removal of the “Seal of Liability” represents the proof of the full, direct, careful and conscious acknowledgment of the entire content of this “INSTALLATION, USE and MAINTENANCE GUIDEBOOK” included within the product packaging. In particular, it represents the full acknowledgment of the whole parts and paragraphs highlighted by the words “ **WARNING!**” or “ **WARNING! DANGER!**” regarding the risks raising within the use of the product itself for the User and/or third parties and the producer “PRODUCT LIABILITY LIMITATIONS” clauses.

In the event that the “Seal of Liability” is not present on the purchased binding, please **DO NOT USE** the product and immediately contact ATK RACE S.R.L. at the e-mail address “customer-care@atkbindings.com” and wait for further instructions.

The “Original User” assumes the absolute responsibility of delivering this “INSTALLATION, USE and MAINTENANCE GUIDEBOOK” to any secondary users of this product (even if temporary) and to verify that they have received the correct training on how to use the product as well as having fully and unequivocally understood the whole parts of this manual.

ATK® BINDINGS products are born from accurate design studies, from the application of the most innovative mechanical processing techniques, and are entirely designed, developed and manufactured within our company in Fiorano Modenese (Modena, Italy). They meet the needs of all those who consider fundamental the requirements that distinguish the entire range of ATK BINDINGS® products: lightness, performance and reliability.

However, for your own personal interest and safety, please read the warnings carefully and follow the instructions below.

⚠ WARNING!

The images included within this manual are purely illustrative. The images may show accessories not included in the product package, such as adjustment plates. ATK RACE S.R.L. reserves the right to make any changes to the technical or graphic design of the product at any time.

1 | BINDING MAIN PARTS

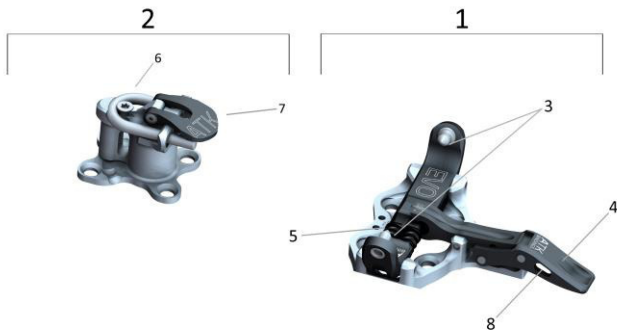

BINDING MAIN PARTS

- | | |
|----------------------------|--------------------------|
| 1. TOE PART | 7. ADJUSTABLE HEEL COVER |
| 2. HEEL PART | 8. LEASH HOLLOW |
| 3. TOE HOOKING PINS | |
| 4. TOE FRONT LOCKING LEVER | |
| 5. CRAMPONS SLOT SEAT | |
| 6. TITANIUM "U" SPRING | |

SCREWS



L13 MM SCREWS FOR TOES

L11 MM SCREWS FOR HEELS

WHAT WILL YOU FIND INTO THE PRODUCT BOX?

NR. 2 TOES, NR. 2 HEELS, NR.1 "SEAL OF LIABILITY" applied to the product, NR. 8 TOE SCREWS 13 mm, NR. 8 HEEL SCREWS 11 mm WITH ONE 4 MM SPACER, NR.1 "WARNING STICKER", NR. 1 "INSTALLATION, USE and MAINTENANCE GUIDEBOOK", NR. 1 "ATK BINDINGS" STICKER.

2 | GENERAL WARNINGS AND RECOMMENDATIONS



WARNING! DANGER!

Before proceeding with any use, please make sure that you have fully understood what is written and explained in this "INSTALLATION, USE and MAINTENANCE GUIDEBOOK".

In case of any doubts and/or uncertainties, please contact ATK® at the e-mail address "customer@atkbinding.com" for additions or clarifications regarding any content of the manual.



WARNING! DANGER!

**The "SL EVO" bindings DO NOT COMPLY WITH ANY DIN/ISO SAFETY STANDARD.
In particular, these bindings do not comply with DIN/ISO 11088 and/or DIN/ISO 13992 safety standards.**

Therefore, the release systems offered by the "SL EVO" bindings could fail in releasing the boot when necessary and/or expected with a consequent greater danger for the User's safety.



WARNING! DANGER!

- The "SL EVO" binding is conceived, developed and produced **for ski mountaineering competitions**. The high performances and the extreme lightness required to this product can influence and/or **reduce the safety features** of the product itself, including the quality or repeatability of the boot release in the event of a fall.
- The "SL EVO" binding can only be used in combination **with "RACE" category boots**, with standard "tech" inserts and general geometries that comply with market standards.
- The "SL EVO" binding provides with **non-adjustable** release systems in the heel part that are pre-calibrated by the factory at fixed values. These values have been defined in the years thanks to the experience raising from years of on-field tests and partnerships with the strongest ski-mountaineering World Champions.
- **The user**, by removing the "SEAL OF LIABILITY" from the binding, **consciously assumes all the responsibility raising from the use of this product**, and therefore releases **ATK RACE S.R.L.** from any damage caused to himself and/or third parties during the use of the product.

- Please, be aware that ski mountaineering, like many other high mountain activities, is a **DANGEROUS SPORT**, that may cause injuries to the ski mountaineer itself and/or third-party.
- In the practice of ski mountaineering, dangerous and/or unpredictable situations may occur; never overestimate your capabilities, never ski if sick or wounded or under the effect of alcohol, medicines or drugs.
- The ATK® bindings are realized for, and tested in combination with, boots provided with standard **“TECH INSERTS”** in perfect state and original dimensions; the use of boots with **NON-STANDARD** and/or worn **“TECH INSERTS”** could modify the functional performance of the bindings and create a great danger for the User. Before any use check the general condition of the gear: in case of doubts immediately reach a **“SPECIALIZED TECHNICIAN” (definition at chapter 3)** for a deeper check or an ATK® dealer for to start up a **FACTORY SERVICE PROCESS®**.
- Installation, adjustment and setting operations on these bindings must be exclusively performed by a **“SPECIALIZED TECHNICIAN”**: any operation performed by a **“NON-SPECIALIZED TECHNICIAN”** is strongly un-recommended and could lead to greater risks for the User’s safety.
- During transport (ex: car roof, backpack, bike) the bindings could be attacked by dirt or salt that may damage the bindings or modify the regular functioning of the same: always protect the bindings with adequate instruments by these external agents during transport.
- After hooking the boot, always check that the toe pins are correctly matching with their seats on the TECH INSERTS by rotating the boot a few times on the toe piece, as shown at chapter 4 and 5.
- Before skiing, please remember to place the toe front lever in downhill position. Skiing with the front lever in uphill position eliminated the lateral release function of the binding with greater risks for the User’s safety. A toe release with the front lever locked in uphill mode would lead to heavy structural damages on the product, with consequent greater danger for the user (**please note paragraph 5.2**).
- Before each use check that the binding or the accessories do not have defective, worn or damaged parts, that the release system is perfectly working and that the bindings have not been contaminated by debris or ice/snow.
- **Never use bindings with damaged parts**: if there is any defective or broken part, or any doubt is raising in your mind in regards to the state of your bindings, immediately stop the use of the product and promptly reach a **“SPECIALIZED TECHNICIAN”** for a deeper check or an ATK® dealer for to start up a **FACTORY SERVICE PROCESS®**.
- Frequently check that: 1) the binding is correctly fixed to the ski 2) that the screws are correctly tightened 3) the ski internal structure is not damaged 4) the ski is flat in the binding mounting area in order to get a perfect matching with the binding base plates. If one or more of these conditions are not confirmed, or cannot be confirmed by the User, please immediately stop the use of your ski-set and promptly bring it to **SPECIALIZED TECHNICIAN** for a deeper check and avoid structural damages to the binding and greater risks for the users, or to an **ATK® DEALER** to start up a **FACTORY SERVICE PROCESS®**.
- The use of a ski brake (**“TOURING SKI BRAKE”** code SK086P) or a leash (**“KEVLAR® CORE LEASH”** code SBC02) is strongly recommended, **in order to limit the risk** of losing the skis and/or create damages to the gear or third parties.
- In case of deep fresh snow or hard snow, the efficiency of any SKI BRAKE is very limited: in these snow conditions the use of a SBC02 | KEVLAR® CORE LEASH is strongly recommended.
- **Any MODIFICATION to components and NON-PROPER USE of any ATK® binding may invalidate the product warranty and raise the risk of injuries for the user and/or third-party.**
- The use of non-original ATK® accessories may cause damages to the bindings with greater risks for the user.
- Safely keep these user’s guide and check it in case of any doubt.

3 | INSTALLATION, SETTING and ADJUSTMENT

WARNING! DANGER!

These bindings and the connected accessories can be exclusively installed, set and/or adjusted by a

“SPECIALIZED TECHNICIAN”

A “SPECIALIZED TECHNICIAN” is any technician operating in the ski/ski touring business field provided with the following minimum requirements:

- 1) Is in possession of the original ATK® “AUTOMATIC DRILLING JIG” (cod. M05) or the “PRINTABLE PAPER TEMPLATE” (latest released version available for download at the product web page) dedicated to the installation of the product and has perfectly understood the entirety of the respective guidebooks.
- 2) Is in possession of the experience, know-how and skills raising from years of practice in the field of “TECH” bindings installations, setting and adjustment.
- 3) Is in possession of the whole instruments and tools needed to perform a state of the art installation, setting and adjustment of an ATK® ski touring “TECH” binding.

The installation, setting and adjustment of an ATK® binding is strictly forbidden to any technician that does not meet the whole 3 above mentioned minimum requirements, because of the greater risks raising from a wrong installation, setting and adjustment.

WARNING! DANGER!

The “SPECIALIZED TECHNICIAN” must be sure that:

- 1) the binding and/or the accessories have been perfectly installed.
- 2) when the “Original User” receives the product, the “SEAL OF LIABILITY” is still complete and correctly applied to the product.
- 3) the “WARNING STICKER” provided with the binding has been applied to the ski top sheet in the area in front of the toe part.
- 4) This “INSTALLATION, USE and MAINTENANCE GUIDEBOOK” is given to the “Original User”.



⚠ WARNING! DANGER!

**M05 “AUTOMATIC DRILLING JIG” bushings combination with M05D back insert
TOE PART: P1-P1-P1-P1 HEEL PART: C-C-C-C**

- After the binding installation, always check the proper distance in between the boot and the heel part of the binding with the 4 mm gauge provided with the binding's screws pack. Proceed as show in the following pictures.

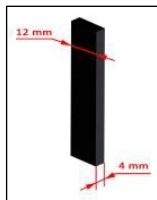

PICTURE 1

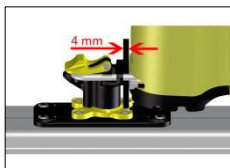

PICTURE 2

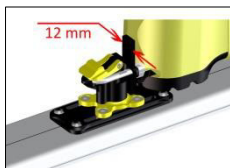

PICTURE 3

If the boot-heel distance is NOT correct (smaller than 3.5mm or bigger than 4.5mm) due to errors occurred during the drilling phase, only one option is available: remove the heel part, install an **ATK® R07** adjustment plate that has the same screw pattern of the **SL EVO** heel part. Then set the proper boot-heel distance thanks to the adjustment range offered by the plate (**the R07 plate for details**).

- A wrong installation distance between boot and binding can cause an early as sudden structural failure of the binding with irreparable damages to the binding/ski/boot system and/or prevent or modify the release performance in the event of a fall with consequent greater risks for the athlete or third parties.
- Always check that the screw length fits with the depth of the drilled holes and with the height of the ski in the mounting area. If the supplied screws do **NOT** match with these requirements, please get in touch with **ATK®** via e-mail at: customercare@atkbindings.com.
- The binding **must be installed on new skis**, with a perfectly flat surface on the mounting area and an internal structural reinforcement for a better screw anchorage.
- Each boot has its own substantial geometry and the installation, setting and adjustment of the binding must be performed with the boot that will be used in combination with the binding itself. In case of boot replacement (with a different one in model or size), a **“SPECIALIZED TECHNICIAN”** must check the setting and adjustment of the binding according to the new boot. If it is not possible to set or adjust the binding for the new boot, a completely new installation, setting and adjustment is required.

3.1 | BOOT-BINDING COMPATIBILITY CHECK

WARNING! DANGER!

In walk mode, the contact point in between the boot and the front locking lever must not exceed the vertical line marked at **PICTURE 4 and 5**.

PICTURE 4 shows a boot which is **COMPATIBLE** with the binding: the boot tip gets in touch with the front lever in a point behind the vertical line marked on the picture.

PICTURE 5 shows a boot which is **NOT COMPATIBLE** with the binding: the boot tip gets in touch with the front lever in a point over (even if slightly) the vertical line marked on the picture.

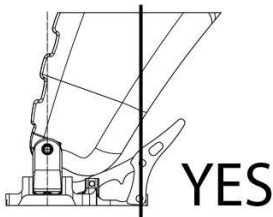

PICTURE 4

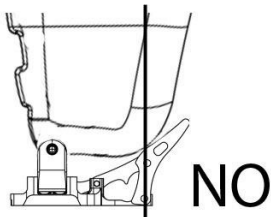

PICTURE 5

The use of a **NON-COMPATIBLE** boot-binding combination is strictly **FORBIDDEN**, due to the high risk of an undesired and/or accidental activation of the front locking lever of the binding that may be moved from **UPHILL WALKING MODE** to **DOWNHILL SKIING MODE** during the uphill walking phase with a great danger for the User's safety.

- Hook the boot at the binding and set it for the uphill walking mode. Rotate the boot on the toe up to the front end of the rotation-range and **verify that the boot is performing at least a 90° free rotation**. If the free rotation range is smaller than 90°, the boot tip and/or the front part of the binding could be damaged by a regular use of the set. (**PICTURE 6**).

**BOOT FREE
ROTATION
RANGE
>=90°**

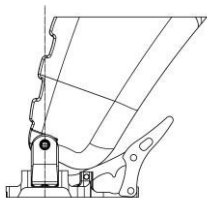

PICTURE 6

WARNING! DANGER!

The ATK® “SL EVO” bindings **DO NOT COMPLY WITH ANY DIN/ISO SAFETY STANDARDS**, in particular these bindings do not comply with DIN/ISO 11088 nor DIN/ISO 13992.

- “SL EVO” bindings offer a **VERTICAL RELEASE SYSTEM (My)** and a **LATERAL RELEASE SYSTEM (Mz)**, both performed by the heel part and pre-calibrated at a non-adjustable fix value during the factory assembly phases.
- In original conditions, the vertical release value (My) of the binding is pre-calibrated at around 9.
- In original conditions, the lateral release value (Mz) of the binding is pre-calibrated at around 8.
- The release values must be considered as indicative: the real release value may sensibly differ from the indicated one, variate during the entire life of the product, due to the use conditions and wear and tear.
- The vertical release (My) is driven by the “**TITANIUM**” “**U**” spring installed on the heel head: the release takes place thanks to the divarication of the “U” spring when the “U” spring is subjected to a sufficient vertical extraction load.
- The lateral release (Mz) is driven by an elastic mean placed inside of the heel: the release takes place thanks to the rotation of the heel head when the system is subjected to a sufficient lateral load.
- These bindings do not provide any different release than vertical (My) and lateral (Mz) ones.
- While skiing, the front locking lever of the binding must be set in “**DOWNHILL MODE**”. Skiing with the front lever set in “**UPHILL MODE**”, the lateral release system is completely disabled, with a greater risk for the user.

5 | PRACTICAL USE INSTRUCTIONS



WARNING! DANGER!

- It is highly recommended to strictly follow the operations described and illustrated in this chapter: a wrong comprehension or execution of these procedures may create a greater risk for the user and/or third parties, such as damages to the gear itself.
- Before proceeding with any operation, verify that the boots and the bindings are **COMPLETELY FREE** from ice, dirt, debris or any other foreign body that may lead to a failure in the regular functions of the bindings.
- Before proceeding with any operation, check the functional state and the wear condition of the binding and its components: in case of doubts regarding the perfect functionality of one or more of the binding's components, immediately stop using the product and promptly reach a **"SPECIALIZED TECHNICIAN"** for a deeper check or an **ATK®** dealer for to start up a **FACTORY SERVICE PROCESS®**.
- Some functions of the binding can be handled with a ski pole. The use of a ski pole may create scratches and/or an early wear of the product surfaces.
- The binding includes some powerful elastic systems. An involuntary, wrong or uncaredful activation of these system is dangerous for the User's or third party's safety. Always handle these bindings with the proper care.
- **Keep these bindings out of reach of children.**

5.1 | UP-HILL/WALKING MODE



WARNING! DANGER!

- In this modality, the toe part is locked on the boot. This means that in case of fall, avalanche or any other unlucky situation that can be faced by the user, the release of the boot will be nearly impossible. This condition represents a **GREAT DANGER** for the user that could be dragged into an avalanche by the ski and/or suffer serious injuries in case of fall or accident.
- When the binding is set in up-hill mode, the separation between boot and binding can only occur in case of heavy material deformations due to an event, external load or particular stress: if this happens, immediately stop using the product and promptly reach a **"SPECIALIZED TECHNICIAN"** for a deeper check or an **ATK®** dealer for to start up a **FACTORY SERVICE PROCESS®**.
- During the ascent, an accidental impact or any other particular event, may move the front locking lever of the binding from the uphill walking mode to the downhill skiing mode. This represents a great danger for the user's safety that may experience an undesired boot release, with consequent risk of falling or slipping in dangerous conditions: frequently check the correct setting and stabilization of the front lever of the binding, especially in case of accidental impact.

- Check that the heel is positioned as shown at **PICTURE A**, with the hooking pins pointing towards the ski tip and the heel flap properly placed and stabilized on the same pins.

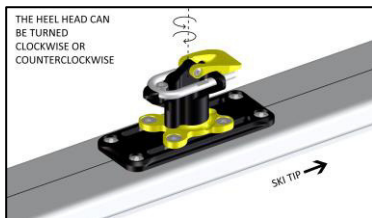

PICTURE A

- Check that the toe part is positioned as shown at **PICTURE B**, ready to receive the boot, free from ice, snow or other debris. If toe is not in the proper position, manually press on the front locking lever in order to reach the stabilized position shown at **PICTURE B**.

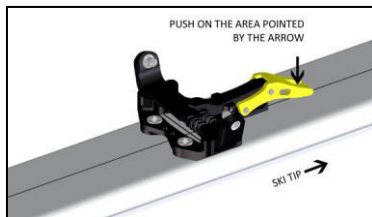

PICTURE B

- Move the boot tip towards the toe part, matching the front TECH insert seats with the toe hooking pins (**PICTURE C**). From this position, vertically push on the toe part to step in. (**PICTURE D/E**).



PICTURE C

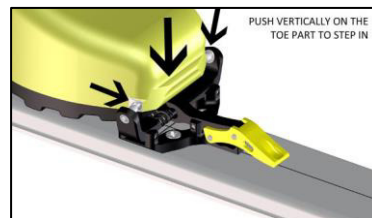

PICTURE D

- Rotate a few times the boot in order to check the proper boot-binding pins coupling, as shown at **PICTURE E**.

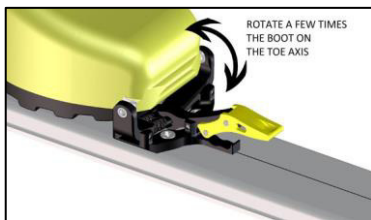

PICTURE E

- Slightly pull the front locking lever towards the boot tip up to the uphill stabilized position in order to lock the binding on the boot and allow the ascent, as shown at **PICTURE F**.

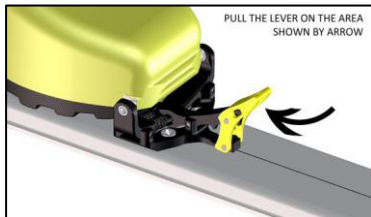

PICTURE F

- **WARNING! Always check that the front locking lever is stabilized in the position shown at PICTURE G.**

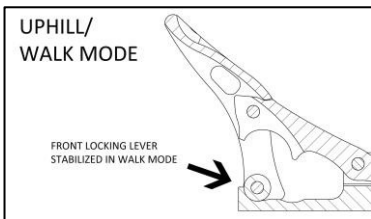

PICTURE G

5.2 | DOWN-HILL MODE

WARNING! DANGER!

- The correct setting of the binding for the DOWNHILL MODE is explained at paragraph 5.2 of this manual. This use modality may allow the release of the binding in case of ruinous falls: **NEVER SKI with the binding set for the UP-HILL WALKING MODE** in order to avoid the deactivation or exclusion of the release systems of the binding!
 - **It is absolute responsibility of the user to decide which behaviour/use modality represents a MINOR RISK for its own safety and that one of third parties, according to the faced conditions.**
 - While skiing, an accidental impact or any other particular event, may move the front locking lever of the binding from the downhill skiing mode to the uphill walking mode. This can happen suddenly and without any voluntary action of the user: frequently check the position of the front locking lever, especially in case of accidental impact.
-
- Check that the heel is positioned as shown at **PICTURE H**, with the hooking pins pointing towards the ski tip. Then rotate the heel flap towards the ski tail up to the back end of the rotation range.

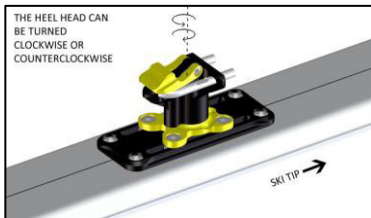

PICTURE H

- Check that the toe part is positioned as shown at **PICTURE I**, ready to receive the boot, free from ice, snow or other debris. If toe is not in the proper position, manually press on the front locking lever in order to reach the stabilized position shown at **PICTURE I**.

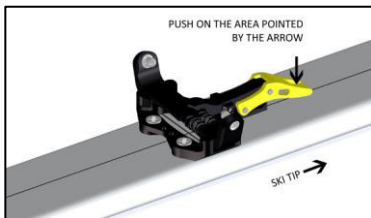

PICTURE I

- Move the boot tip towards the toe part, matching the front TECH insert seats with the toe hooking pins (**PICTURE L**). From this position, vertically push on the toe part to step in. (**PICTURE M/N**).

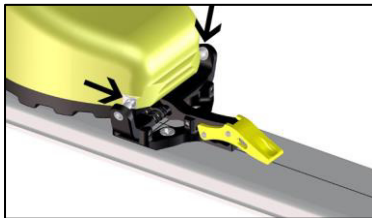

PICTURE L

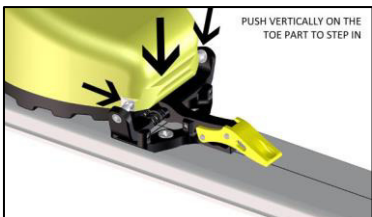

PICTURE M

- Rotate a few times the boot in order to check the proper boot-binding coupling, as shown at **PICTURE N**.

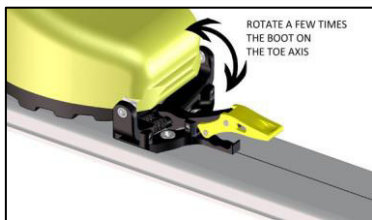

PICTURE N

- Check that the front locking lever is in downhill skiing mode, as shown at **PICTURE O**; if not like that, slightly push on the front locking lever in order to obtain the proper position, as shown at **PICTURE O**.

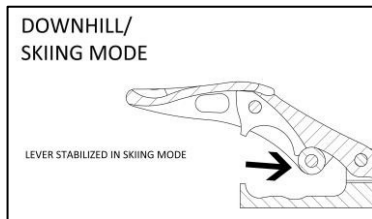

PICTURE O

- Press on the heel part of the binding in order to step in and to obtain the complete hooking of the boot, as shown at **PICTURE P**.

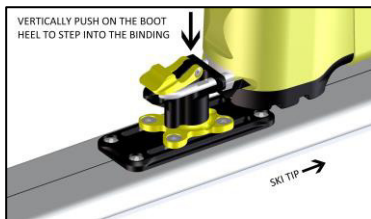

PICTURE P

5.3 | HOW TO GET OUT FROM THE BINDING

WARNING! DANGER!

While releasing the binding, **firmly hold the ski that is going to be release from the boot** in order to avoid an uncontrolled ski loss that would represent a great danger for the skier and/or third parties which may be hit by the ski.

- By the up-hill position, press on the front locking lever as show at **PICTURE Q**, moving it to the downhill skiing position and proceed as follows.

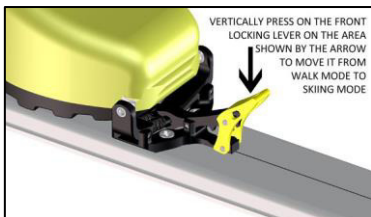

PICTURE Q

- By the downhill skiing position, press again the front locking lever as shown at **PICTURE R**, in order to fully open the toe part and release the boot.

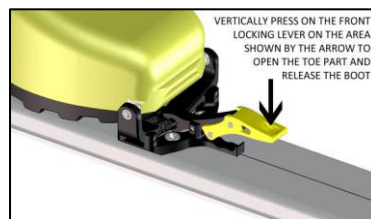

PICTURE R

- Lift and rotate the foot tip moving the boot forward in order to get out from the heel part of the binding, as shown at **PICTURE S**.

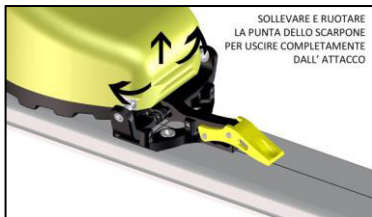

PICTURE S

6 | "SL EVO" BINDING ACCESSORIES

The **ATK®** collection is completed by a series of accessories that increase the comfort and performance of the bindings; these accessories and the information about the same can be found at the corporate webpage www.atkbindings.com

7 | HOW TO INSTALL THE OPTIONAL CRAMPONS SLOT (COD. SRA)

⚠ WARNING! In case of first installation, it is strongly recommended to fix the “SRA” crampons slot on the toe part before fixing the toe part on the ski.

⚠ WARNING! In case of intensive use of the crampons, the central elastic holding mean could lose its effectiveness due to wear and tear of the material. Always check the proper and solid central stabilization when matching the crampons on the SRA crampons slot.

- Check that the crampons slot seat is free from debris or dirt that may affect the correct positioning of the slot; otherwise, clean it with a proper tool.
- Insert the slot into its seat (**PICTURE T**), checking the perfect matching of the two shapes of the support and the base plate of the toe part; check that the screw holes on the support are fully visible from above through the respective holes on the toe base plate (**PICTURE U**).

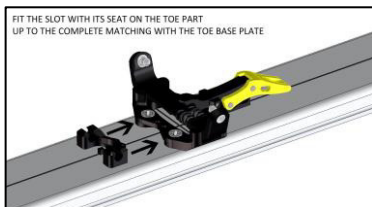

PICTURE T

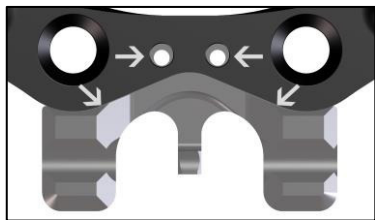

PICTURE U

- Fix the slot with the supplied screws using a high quality TORX 10 insert at a torque of 1 N/m, as shown at **PICTURE V**.

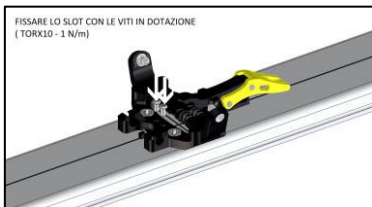

PICTURE V

WARNING! DANGER!

THE MAXIMUM CRAMPON SIZE THAT CAN BE USE ON THE SRA CRAMPONS SLOT IS 97mm (RA097)

- Crampions must be used only with proper snow conditions; improper snow conditions could lead to heavy damages to the material and create a greater danger for the user or third parties.
- **Do not force the crampon when not properly placed into its seat.**

- Place the crampon at 90° and slip it into the proper seat of the CRAMPONS SLOT, as shown at **PICTURE X**.
- Once having correctly placed the crampon in its seat, release the crampon in order to obtain the position shown at **PICTURE Y**.
- **Manually test the lateral stabilization of the crampon and the free rotation of the same on its pivot, as shown at PICTURE Y.**

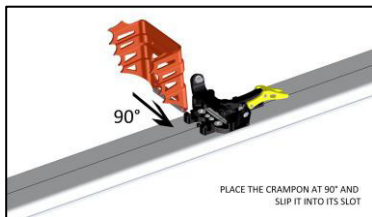

PICTURE X

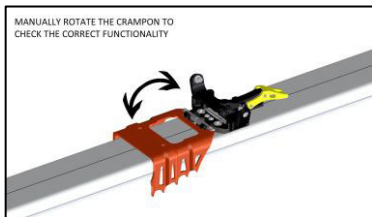

PICTURE Y

9 | CARE, MAINTENANCE AND STORAGE

- Some of the “**SL EVO**” bindings parts are subjected to wear and tear. Original Spare Parts can be purchased by the User through the an **ATK® DEALER** and **have them installed exclusively by a “SPECIALIZED TECHNICIAN”**:
 - **TITANIUM “U” SPRINGS (CODE K08W)**: depending on the use intensity and physical characteristics of the User, these “U” springs may show a regular such as fast wear and tear in the contact area with the boot tech insert. These springs must be replaced when the minimal section goes under 2.5 mm, which is the half of the original section.
 - **HEEL COVERS (CODE K07.5W)**: depending on the use intensity and physical characteristics of the User, these heel covers may show a wear and tear or be damaged in the contact area with the boot sole/tech insert. These heel covers must be replaced when worn or damaged.
- In order to maintain a perfect functionality of the product, including the efficiency of the release systems, **ATK®** recommends to periodically lubricate all the joints and rotating contact parts of the binding with the **ORIGINAL ATK® GREASE (COD. SG01)** that can be purchased through any **ATK®** dealer; lubricating instructions and basic maintenance guidebooks can be found at the respective webpage of the interested binding (www.atkbindings.com)
- After a medium to long period of inactivity, it is necessary to have the binding checked by an “**SPECIALIZED TECHNICIAN**”, in particular the general wear and tear of the binding, the proper functionality of the systems and the lubrication state of the product.
- After each use, carefully clean the binding from dirt, salt, sand or debris, using distilled water; do not use spears or harsh chemical solvents.
- When not used, set the binding as per the downhill mode in order to preserve the elasticity of the springs. Store it in a dry and protective place; avoid excessive heat.
- Do not make any modifications or tampering to the bindings: any of these actions will lead to the cancellation of the product warranty; these actions could also compromise the functionality of the bindings and increase the possibility of structural damages and therefore create a greater risk for the user’s and third party’s safety.
- **Within 4 years from the purchase of the product**, and every 2 years thereafter, the binding must be submitted to an **OFFICIAL ATK® REVISION PROCESS** in order to check the good state of the product parts and the proper functionality of the whole systems.

The **OFFICIAL ATK® REVISION PROCESS** activation can be required to **ATK®** with the help of an **ATK® DEALER** or by filling the online form that can be found at the web-page: <https://www.atkbindings.com/en/technical-support/>

10 | ATK WARRANTY TERMS

ATK® guarantees that the product is free from any manufacturing or material defects for a period of two years (2) (pursuant to Italian Legislative Decree n. 24/02) starting from the date of purchase throughout an authorized dealer of ATK® products. The effective date of the warranty must be supported by the proof of purchase: without the original proof of purchase, the temporal effect will start from the date in which the product left the ATK® warehouses.

The 24 months warranty (pursuant to Italian Legislative Decree n. 24/02) is applied to each product that shows a conformity defect, if properly installed, set, adjusted and used in the respect of its destination of use and considering the content of the whole documentation provided by the producer with the product, including, but not limited to, the "INSTALLATION, USE AND MAINTENANCE GUIDEBOOK", the "SEAL OF LIABILITY" applied to the product and the "WARNING STICKER" to be applied to the ski.

This warranty, in accordance with Italian Legislative Decree n. 24/02, is granted only to Privat consumers (a person who buys goods for purposes not related to his professional activity, therefore purchases the product without any reference to a VAT code).

Known that the ATK® bindings are NOT SAFETY CERTIFIED by any certification institute, since they DO NOT COMPLY WITH ANY DIN/ISO SAFETY STANDARD, the warranty is not valid in case of:

- Wrong installation or installation performed by a NON "SPECIALIZED TECHNICIAN" (see chapter 3);
- Wrong use;
- Lacking of periodical maintenance as stated at chapter 9 of this GUIDEBOOK;
- Carelessness;
- Inexperienced use;
- Any modification performed on the product;
- Purchase through a non-ATK® Dealer (ATK® updated dealers list: <https://www.atkbindings.com/en/resellers/>);
- Warranty request from a NON-ORIGINAL USER (=second hand product);
- Overuse;
- Wear and tear on consumables, available as regular spare parts

ATK® does not recognize any express or implied warranties other than those specified in this chapter and does not recognize damages raising by:

- Wrong installation, setting and adjustment;
- Standard wear and tear, including chipping;
- Wrong set up;
- Use in combination with non-adequate gear per definition or due to wear and tear;
- Use in combination with boots not expressly designed to be used in combination with tech bindings and/or boots that do not comply with the standard TECH system.
- Impacts or collisions with foreign bodies;
- prejudices not directly or necessarily related to the product;
- prejudices connected to the noncompliance with any DIN/ISO SAFETY standard;
- prejudices anyway avoidable with due caution required by the raw mountain environment with low urbanization;
- prejudices increased by the damaged subject behaviour.

A warranty process activation can be required by the consumer through an ATK® DEALER or through the **ONLINE FORM** that can be found at the webpage <https://www.atkbindings.com/en/technical-support/>.

In case that all the warranty conditions are satisfied, the warranty case will be opened and ATK® will provide the best support possible to have the process closed in the fastest time possible.

Based on the product state, **ATK®** will be free to choose the best solution in between replacing the full product, a part of the same or just repair it.

An additional warranty period of 6 months is granted on the parts replaced by **ATK®** during an official service operation, does not matter if under warranty, partial warranty or the customer charge.

In case that the warranty case requires the delivery of the product to the company, the product itself must be returned inside the original box, complete in all its parts.

No refund can be asked to **ATK®** for eventual delays in the procedures under warranty conditions.

The "DEMO/TEST" bindings are intended for an unusual and particularly intensive use, which may modify the lasting performance of the product, accelerating the wear and tear of the product itself. The warranty period on the "DEMO/TEST" products is reduced to one (1) year after the purchasing date;

Free-of-charge or loan of use products are fully excluded by any warranty application.

For any further information and/or clarification regarding the functionality of the products and the activation of the warranty operations, please contact **ATK®** at:

customercare@atkbinding.com

11 | LIMITATION OF LIABILITY ON THE PRODUCT

WARNING! DANGER!

The USER is fully aware that the **ATK®** bindings

DO NOT COMPLY WITH ANY DIN/ISO SAFETY STANDARD.

In particular, these do not comply with DIN/ISO 11088 and DIN/ISO 13992 safety standards.

By purchasing such products in a conscious and informed way as provided by this "INSTALLATION, USE and MAINTENANCE GUIDEBOOK", the USER expressly accepts without any reserve all the risks arising from the characteristics of the products, relieving **ATK®** by any liability regarding eventual damages caused to the user or third parties during the use of the product itself.

ATK RACE S.r.l. communicates that the pictures and descriptions included in this catalogue are indicative; ATK RACE® S.r.l. has the right to modify or delete each product or process described in this guidebook.

ATK BINDINGS

SL EVO WORLD CUP

(M.Y. 2019) - 110 GR

